

Zeus 4 axis is our CNC leading profile machining center developed to satisfy the most demanding production requirements across a broad range of industrial applications. The Zeus 4 axis series has been designed for drilling, milling and tapping operations on profiles made of aluminium, steel and light alloys.

Technical features:

- Robust structures made of electro-welded steel, tempered and worked with CNC machine tools.
- 4-Axis movement controlled by high-precision brushless servomotors.
- The 4 axis series features a tilting head providing $\pm 90^\circ$ of spindle tilt.
- High-powered electrospindle (10 kw in S1), with HSK F63 tool connection and liquid cooled for hard removal processes during milling and drilling operations.
- Tool magazine holding up to 16 tools, placed on the back side of the moving portal.
- Milling cutter diam. 120 mm.
- Clamp movement automatically set, controlled by CNC (optional: independent clamp positioning).
- Standard versions 4, 7 and 9 meters.
- Double working area (version 7 and 9 meters).
- Chip conveyor plate placed below the working area.
- Safety light curtains system located in front of the machine.

The specifications and illustrations in this catalogue are only a guide, Dynamic Machines Services Sdn Bhd therefore reserves the right to make any modifications it deems necessary for technical or commercial reasons.

MAXIMUM SIZE MACHINABLE WITH VERTICAL TOOL IN POSITIONS 0°/+90°/-90°

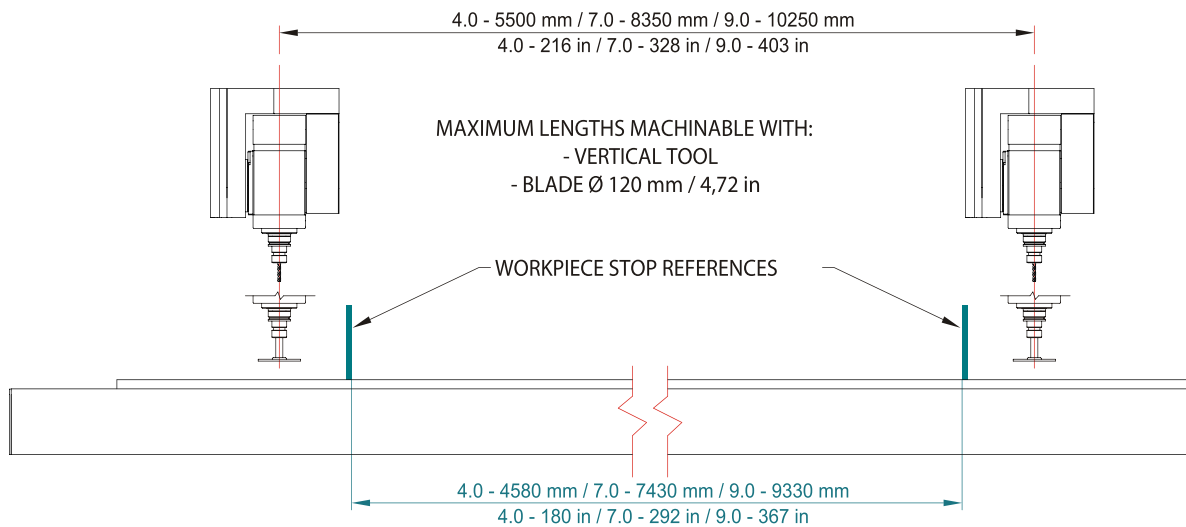
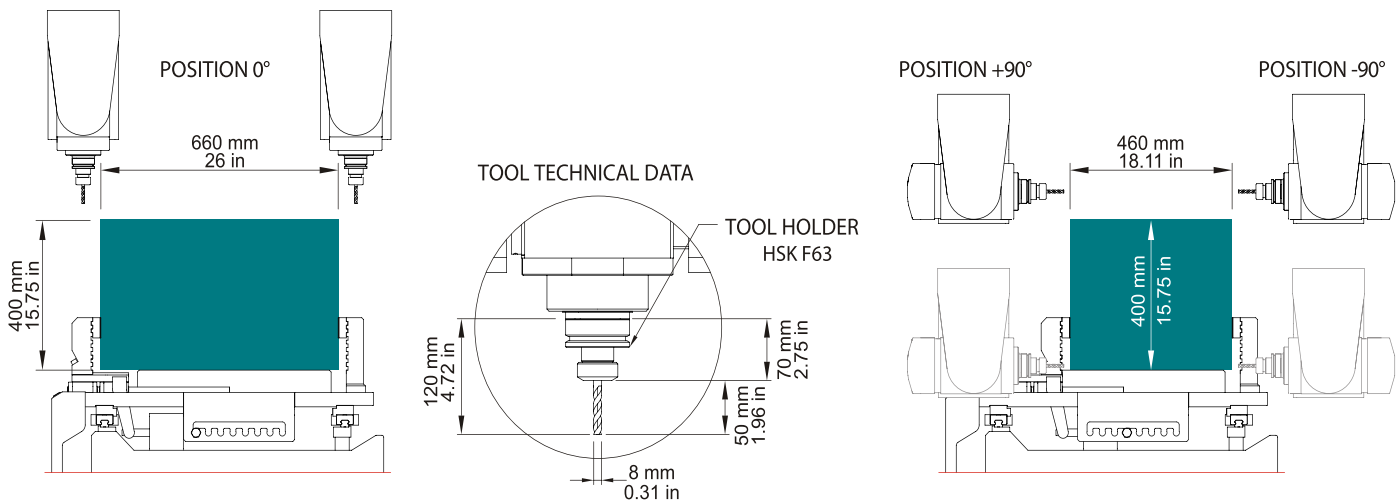

Description	Zeus 4 axis 4.0 - 7.0 - 9.0 version	Description	Zeus 4 axis 4.0 - 7.0 - 9.0 version
X AXIS LONGITUDINAL	4580 - 8350 - 10250 mm 180.3 - 328.7 - 403.5 in	NUMBER OF STOP REFERENCES STANDARD	2 4 optional (7.0 - 9.0 version)
Y AXIS CROSS	1385 mm 54.5 in	VOLTAGE	400 V triphase - 50/60 Hz
Z AXIS VERTICAL	750 mm 29.5 in	SPINDLE MOTOR POWER S1	10 kW
A AXIS ROTATION (ROTATION AROUND X AXIS)	from -90° to +90°	ADJUSTABLE ELECTRO SPINDLE SPEED	0-24000 rpm
AXIS POSITIONING SPEED	X 100 m/min Y 60 m/min Z 30 m/min	TOOL HOLDER	HSK F63 DIN 69871
AXIS ACCELERATION	X 3 m/sec ² Y 3 m/sec ² Z 3 m/sec ²	SPINDLE COOLING SYSTEM	liquid
TOOL MAGAZINE CAPACITY	16 positions	OPERATING PRESSURE	6-8 bar
MAXIMUM MILLING BLADE DIAMETER	120 mm 4.72 in	TOTAL INSTALLED POWER	18 kW
NUMBER OF STANDARD VICES	4 (4.0 version) 8 (7.0 - 9.0 version)	OVERALL DIMENSIONS (DxWxH) mm - WEIGHT kg	8380x3390x2840 mm - 5500 kg 11230x3390x2840 mm - 7000 kg 13130x3390x2840 mm - 8500 kg
VICES POSITIONING	automatic	OVERALL DIMENSIONS (DxWxH) in - WEIGHT lb	330x133.5x112 in - 12100 lb 442x133.5x112 in - 15400 lb 517x133.5x112 in - 18700 lb

The specifications and illustrations in this catalogue are only a guide, Dynamic Machines Services Sdn Bhd therefore reserves the right to make any modifications it deems necessary for technical or commercial reasons.